

CENTRAL MACHINERY®
18" DRUM SANDER
Model 98198

SET UP AND OPERATING INSTRUCTIONS



Distributed exclusively by Harbor Freight Tools®.

3491 Mission Oaks Blvd., Camarillo, CA 93011

Visit our website at: <http://www.harborfreight.com>



**Read this material before using this product.
Failure to do so can result in serious injury.
SAVE THIS MANUAL.**

Copyright© 2008 by Harbor Freight Tools®. All rights reserved. No portion of this manual or any artwork contained herein may be reproduced in any shape or form without the express written consent of Harbor Freight Tools. Diagrams within this manual may not be drawn proportionally. Due to continuing improvements, actual product may differ slightly from the product described herein.

For technical questions or replacement parts, please call 1-800-444-3353.

CONTENTS

IMPORTANT SAFETY INFORMATION	3
GENERAL POWER TOOL SAFETY WARNINGS.....	3
DRUM SANDING OPERATIONS SAFETY WARNINGS .	5
GROUNDING	7
GROUNDED TOOLS: TOOLS WITH THREE PRONG PLUGS	7
DOUBLE INSULATED TOOLS: TOOLS WITH TWO PRONG PLUGS	7
EXTENSION CORDS	8
SYMBOLOLOGY.....	8
SPECIFICATIONS	9
UNPACKING	9
LIST OF CONTENTS.....	9
INSTRUCTIONS FOR PUTTING INTO USE	9
ASSEMBLY.....	9
MOUNTING.....	10
FINAL ASSEMBLY	10
OPERATING INSTRUCTIONS	10
TOOL SET UP	10
WORK PIECE AND WORK AREA SET UP	11
GENERAL OPERATING INSTRUCTIONS	11
MAINTENANCE AND SERVICING	15
CLEANING AND MAINTENANCE ...	15
REPLACING V-BELTS	16

PULLEY ALIGNMENT	16
FEED BELT TRACKING	16
FEED BELT REPLACEMENT	17
CONVEYOR TABLE ADJUSTMENTS	17
TROUBLESHOOTING.....	20
V-BELTS	25
BEARINGS	25
ASSEMBLY DIAGRAM	26
LIMITED 1 YEAR / 90 DAY WARRANTY	27

SAVE THIS MANUAL

Keep this manual for the safety warnings and precautions, assembly, operating, inspection, maintenance and cleaning procedures. Write the product's serial number in the back of the manual near the assembly diagram (or month and year of purchase if product has no number). Keep this manual and the receipt in a safe and dry place for future reference.

IMPORTANT SAFETY INFORMATION

In this manual, on the labeling, and all other information provided with this product:



This is the safety alert symbol. It is used to alert you to potential personal injury hazards. Obey all safety messages that follow this symbol to avoid possible injury or death.

DANGER

DANGER indicates a hazardous

situation which, if not avoided, will result in death or serious injury.

WARNING

WARNING indicates a

hazardous situation which, if not avoided, could result in death or serious injury.

CAUTION

CAUTION, used with the safety

alert symbol, indicates a hazardous situation which, if not avoided, could result in minor or moderate injury.

NOTICE

NOTICE is used to address practices not related to personal injury.

CAUTION

CAUTION, without the safety alert symbol, is used to address practices not related to personal injury.

General Power Tool Safety Warnings



WARNING Read all safety warnings and instructions.

Failure to follow the warnings and instructions may result in electric shock, fire and/or serious injury.

Save all warnings and instructions for future reference.

The term "power tool" in the warnings refers to your mains-operated (corded) power tool or battery-operated (cordless) power tool.

1. **Work area safety**
 - a. **Keep work area clean and well lit.** *Cluttered or dark areas invite accidents.*
 - b. **Do not operate power tools in explosive atmospheres, such as in the presence of flammable liquids, gases or dust.** *Power tools create sparks which may ignite the dust or fumes.*
 - c. **Keep children and bystanders away while operating a power tool.** *Distractions can cause you to lose control.*
2. **Electrical safety**
 - a. **Power tool plugs must match the outlet. Never modify the plug in any way. Do not use any adapter**

- plugs with grounded power tools.** *Unmodified plugs and matching outlets will reduce risk of electric shock.*
- b. Avoid body contact with grounded surfaces such as pipes, radiators, ranges and refrigerators.** *There is an increased risk of electric shock if your body is grounded.*
 - c. Do not expose power tools to rain or wet conditions.** *Water entering a power tool will increase the risk of electric shock.*
 - d. Do not abuse the cord. Never use the cord for carrying, pulling or unplugging the power tool. Keep cord away from heat, oil, sharp edges or moving parts.** *Damaged or entangled cords increase the risk of electric shock.*
 - e. When operating a power tool outdoors, use an extension cord suitable for outdoor use.** *Use of a cord suitable for outdoor use reduces the risk of electric shock.*
 - f. If operating a power tool in a damp location is unavoidable, use a Ground Fault Circuit Interrupter (GFCI) protected supply.** *Use of a GFCI reduces the risk of electric shock.*
- 3. Personal safety**
- a. Stay alert, watch what you are doing and use common sense when operating a power tool. Do not use a power tool while you are tired or under the influence of drugs, alcohol or medication.** *A moment of inattention while operating power tools may result in serious personal injury.*
 - b. Use safety equipment. Always wear ANSI-approved eye protection and full-face shield.** *Safety equipment such as dust mask, non-skid safety shoes, hard hat, or hearing protection used for appropriate conditions will reduce personal injuries.*
- c. Prevent unintentional starting.** **Ensure the switch is in the off-position before connecting to power source, picking up or carrying the tool.** *Carrying power tools with your finger on the switch or energizing power tools that have the switch on invites accidents.*
 - d. Remove any adjusting key or wrench before turning the power tool on.** *A wrench or a key left attached to a rotating part of the power tool may result in personal injury.*
 - e. Do not overreach. Keep proper footing and balance at all times.** *This enables better control of the power tool in unexpected situations.*
 - f. Dress properly. Do not wear loose clothing or jewelry. Keep your hair, clothing and gloves away from moving parts.** *Loose clothes, jewelry or long hair can be caught in moving parts.*
 - g. If devices are provided for the connection of dust extraction and collection facilities, ensure these are connected and properly used.** *Use of these devices can reduce dust-related hazards.*
- 4. Power tool use and care**
- a. Do not force the power tool. Use the correct power tool for your application.** *The correct power tool will do the job better and safer at the rate for which it was designed.*

- b. **Do not use the power tool if the switch does not turn it on and off.** *Any power tool that cannot be controlled with the switch is dangerous and must be repaired.*
- c. **Disconnect the plug from the power source and/or the battery pack from the power tool before making any adjustments, changing accessories, or storing power tools.** *Such preventive safety measures reduce the risk of starting the power tool accidentally.*
- d. **Store idle power tools out of the reach of children and do not allow persons unfamiliar with the power tool or these instructions to operate the power tool.** *Power tools are dangerous in the hands of untrained users.*
- e. **Maintain power tools. Check for misalignment or binding of moving parts, breakage of parts and any other condition that may affect the power tool's operation. If damaged, have the power tool repaired before use.** *Many accidents are caused by poorly maintained power tools.*
- f. **Keep cutting tools sharp and clean.** *Properly maintained cutting tools with sharp cutting edges are less likely to bind and are easier to control.*
- g. **Use the power tool and accessories in accordance with these instructions, taking into account the working conditions and the work to be performed.** *Use of the power tool for operations different from those intended could result in a hazardous situation.*

5. Service

- a. **Have your power tool serviced by a qualified repair person using only identical replacement parts.** *This will ensure that the safety of the power tool is maintained.*

Drum Sanding Operation Safety Warnings

1. **This power tool is intended to function as a wood sander. Read all safety warnings, instructions, illustrations and specifications provided with this power tool.** Failure to follow all instructions listed below may result in electric shock, fire and/or serious injury.
2. **Operations such as grinding, wire brushing or polishing are not recommended to be performed with this power tool.** Operations for which the power tool was not designed may create a hazard and cause personal injury.
3. **Do not use accessories which are not specifically designed and recommended by the tool manufacturer.** Just because the accessory can be attached to your power tool, it does not assure safe operation.
4. **Wear personal protective equipment. Depending on application, use face shield or safety glasses. As appropriate, wear dust mask, hearing protectors, gloves and workshop apron capable of stopping small abrasive or work piece fragments. The eye protection must be capable of stopping flying debris generated by various operations.** The dust mask or respirator must be capable of filtering particles

generated by your operation. Prolonged exposure to high intensity noise may cause hearing loss.

5. **Keep bystanders a safe distance away from work area. Anyone entering the work area must wear personal protective equipment.** Fragments of work piece or of a broken accessory may fly away and cause injury beyond immediate area of operation.
6. **Position the cord clear of the spinning accessory.** If you lose control, the cord may be cut or snagged and your hand or arm may be pulled into the spinning accessory.
7. Maintain labels and nameplates on the tool. These carry important safety information. If unreadable or missing, contact Harbor Freight Tools for a replacement.
8. Avoid unintentional starting. Prepare to begin work before turning on the tool.
9. This product is not a toy. Keep it out of reach of children.
10. People with pacemakers should consult their physician(s) before use. Electromagnetic fields in close proximity to heart pacemaker could cause pacemaker interference or pacemaker failure. In addition, people with pacemakers should:
 - Avoid operating alone.
 - Do not use with power switch locked on.
 - Properly maintain and inspect to avoid electrical shock.
 - Any power cord must be properly grounded. Ground Fault Circuit Interrupter (GFCI) should also be imple-

mented – it prevents sustained electrical shock.

11. Some dust created by power sanding wood products can contain chemicals known [to the State of California] to cause cancer, birth defects or other reproductive harm such as specially treated wood, wood with lead paint in it, and some species of wood have toxic qualities. Some examples of these chemicals are:
 - Lead from lead-based paints
 - Arsenic and chromium from chemically treated lumberYour risk from these exposures varies, depending on how often you do this type of work. To reduce your exposure to these chemicals: work in a well ventilated area, and work with approved safety equipment, such as those dust masks or respirators that are specially designed to filter out microscopic particles. (California Health & Safety Code § 25249.5, *et seq.*)
12. **WARNING:** Handling the cord on this product will expose you to lead, a chemical known to the State of California to cause cancer, and birth defects or other reproductive harm. Wash hands after handling. (California Health & Safety Code § 25249.5, *et seq.*)
13. The warnings, precautions, and instructions discussed in this instruction manual cannot cover all possible conditions and situations that may occur. It must be understood by the operator that common sense and caution are factors which cannot be built into this product, but must be supplied by the operator.



SAVE THESE INSTRUCTIONS.

GROUNDING

⚠️ WARNING TO PREVENT ELECTRIC SHOCK

AND DEATH FROM INCORRECT GROUNDING WIRE CONNECTION:



Check with a qualified electrician if you are in doubt as to whether the outlet is properly grounded. Do not modify the power cord plug provided with the tool. Never remove the grounding prong from the plug. Do not use the tool if the power cord or plug is damaged. If damaged, have it repaired by a service facility before use. If the plug will not fit the outlet, have a proper outlet installed by a qualified electrician.

three prong grounding plug. The plug must be connected to a properly grounded outlet. If the tool should electrically malfunction or break down, grounding provides a low resistance path to carry electricity away from the user, reducing the risk of electric shock. (See 3-Prong Plug and Outlet.)

3. The grounding prong in the plug is connected through the green wire inside the cord to the grounding system in the tool. The green wire in the cord must be the only wire connected to the tool's grounding system and must never be attached to an electrically "live" terminal. (See 3-Prong Plug and Outlet.)
4. The tool must be plugged into an appropriate outlet, properly installed and grounded in accordance with all codes and ordinances. The plug and outlet should look like those in the preceding illustration. (See 3-Prong Plug and Outlet.)

Grounded Tools: Tools with Three Prong Plugs

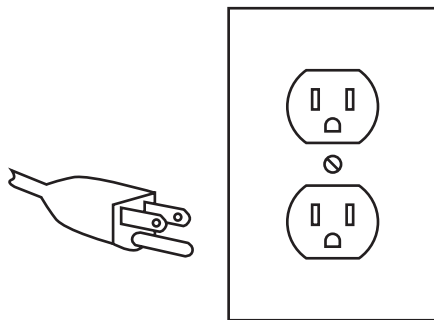

3-Prong Plug and Outlet

1. This Drum Sander comes with a three prong plug.
2. Tools marked with "Grounding Required" have a three wire cord and

Double Insulated Tools: Tools with Two Prong Plugs

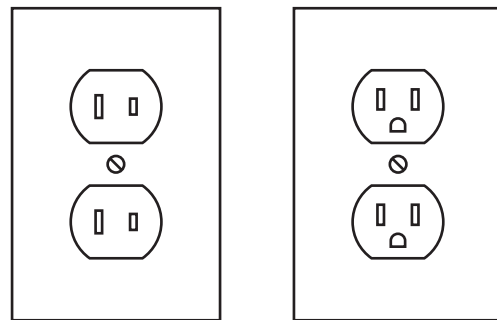

Outlets for 2-Prong Plug

1. Tools marked "Double Insulated" do not require grounding. They have a special double insulation system which satisfies OSHA requirements and complies with the applicable

standards of Underwriters Laboratories, Inc., the Canadian Standard Association, and the National Electrical Code. **(See Outlets for 2-Prong Plug.)**

2. Double insulated tools may be used in either of the 120 volt outlets shown in the preceding illustration. **(See Outlets for 2-Prong Plug.)**

Extension Cords







1. **Grounded** tools require a three wire extension cord. **Double Insulated** tools can use either a two or three wire extension cord.
2. As the distance from the supply outlet increases, you must use a heavier gauge extension cord. Using extension cords with inadequately sized wire causes a serious drop in voltage, resulting in loss of power and possible tool damage. **(See Table A.)** The smaller the gauge number of the wire, the greater the capacity of the cord. For example, a 14 gauge cord can carry a higher current than a 16 gauge cord. **(See Table A.)**
3. When using more than one extension cord to make up the total length, make sure each cord contains at least the minimum wire size required. **(See Table A.)**
4. If you are using one extension cord for more than one tool, add the nameplate amperes and use the sum to determine the required minimum cord size. **(See Table A.)**
5. If you are using an extension cord outdoors, make sure it is marked with the suffix "W-A" ("W" in Canada) to indicate it is acceptable for outdoor use.

6. Make sure the extension cord is properly wired and in good electrical condition. Always replace a damaged extension cord or have it repaired by a qualified electrician before using it.
7. Protect the extension cords from sharp objects, excessive heat, and damp or wet areas.

RECOMMENDED MINIMUM WIRE GAUGE FOR EXTENSION CORDS* (120/240 VOLT)					
NAMEPLATE AMPERES (at full load)	EXTENSION CORD LENGTH				
	25'	50'	75'	100'	150'
0 – 2.0	18	18	18	18	16
2.1 – 3.4	18	18	18	16	14
3.5 – 5.0	18	18	16	14	12
5.1 – 7.0	18	16	14	12	12
7.1 – 12.0	18	14	12	10	-
12.1 – 16.0	14	12	10	-	-
16.1 – 20.0	12	10	-	-	-

TABLE A * Based on limiting the line voltage drop to five volts at 150% of the rated amperes.

Symbology

	Double Insulated
	Canadian Standards Association
	Underwriters Laboratories, Inc.
	Volts Alternating Current
	Amperes
	No Load Revolutions per Minute (RPM)

SPECIFICATIONS

Maximum Stock Width	18" (36" two passes)
Sanding Motor	1-1/2 HP Single Phase, Fan Cooled Induction Motor
Stock Thickness Range	1/8" to 4-1/2"
Electrical Requirements	120 V~ / 60 Hz / 15A
Sanding Drum Speed	4,000 RPM
Dust Collection	2-1/2" Port & Built-In fan
Conveyor Belt speed	Range from 2 - 12 FPM
Net Weight	300 LBS



UNPACKING

When unpacking, check to make sure that the item is intact and undamaged. If any parts are missing or broken, please call Harbor Freight Tools at the number shown on the cover of this manual as soon as possible.

List of contents

Description	Qty
Drum Sander - Pre-assembled	1
Dust Bag (273)	1
Dust Hose Collar (218)	1
Square Dust Port (56)	1
Hex Key 4mm, 5mm, 6mm	3
Double Open-End Wrench	1

Some tools may not be supplied

INSTRUCTIONS FOR PUTTING INTO USE



Read the **ENTIRE IMPORTANT SAFETY INFORMATION** section at the beginning of this manual including all text under

subheadings therein before set up or use of this product.

⚠ WARNING TO PREVENT SERIOUS INJURY FROM ACCIDENTAL OPERATION:
Turn the Power Switch of the tool to its "OFF" position and unplug the tool from its electrical outlet before assembling or making any adjustments to the tool.

Note: For additional information regarding the parts listed in the following pages, refer to the Assembly Diagram near the end of this manual.

Assembly

The Drum Sander.

- a. The Drum Sander comes 95% pre-assembled.

Assemble the stand.

- a. It is easier to assemble upside down.

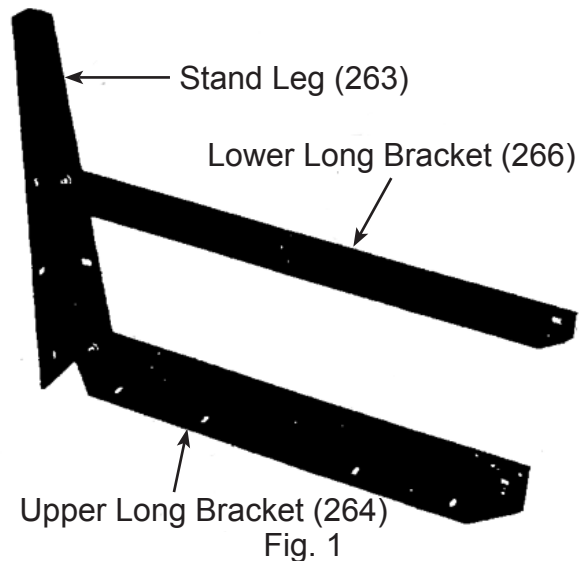

- b. Mount an Upper (264) and Lower Long Bracket (266) to a Stand Leg (263) and loosely attach (See Fig. 1)

with two M8-1.25 x 15 Carriage Bolts (268) and Flanged Nuts (269).

- c. Do not tighten the screws to the Stand until its assembly is complete.

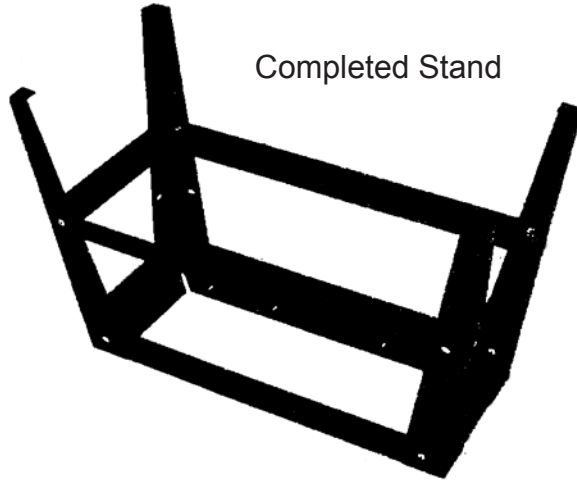

Fig. 2.

- d. Repeat this assembly process with the other three legs, using the supplied hardware, until the Stand (263) assembly is complete. (See Fig. 2.)

Mounting

Attach drum sander to stand.

- a. Lay the Drum Sander on its side with the Hand Wheel (103) facing up.
- b. With the Stand (263) on its side, point the Stand's top toward the sander's bottom,
- c. Move the Stand up against the bottom of the sander and align holes.
- d. Bolt the Sander to the Stand using Hex Bolts (270)/Hex Nuts (271)/Flat Washers (272) in four places.
- e. With bolts securely tightened and the help of another person, tilt the Drum Sander/Stand upright.

Final Assembly

Attach components.

- a. Screw the Hand Wheel Handle onto the Hand Wheel (103).
- b. Attach Hand Wheel (103) with a Hex Socket HD Screw (239) and Flat Washer (238).
- c. Attach the Square Dust Port (56).
- d. Attach the Square-To-Round Dust Chute (59) Adapter and Dust Chute (70).
- e. Attach the Dust Bag (273).

OPERATING INSTRUCTIONS



Read the **ENTIRE IMPORTANT SAFETY INFORMATION** section at the beginning of this manual including all text under subheadings therein before set up or use of this product.

Tool Set Up



TO PREVENT SERIOUS INJURY

FROM ACCIDENTAL OPERATION:

Turn the Power Switch of the tool to its "OFF" position and unplug the tool from its electrical outlet before performing any inspection, maintenance, or cleaning procedures.

- 1. The initial setup and adjustment of the following have been done at the factory:
 - a. V-Belt tensioning.
 - b. Feed Belt tensioning and tracking.
 - c. Table adjustments.

Work Piece and Work Area Set Up

1. Designate a work area that is clean and well-lit. The work area must not allow access by children or pets to prevent injury and distraction.
2. Route the power cord along a safe route to reach the work area without creating a tripping hazard or exposing the power cord to possible damage. The power cord must reach the work area with enough extra length to allow free movement while working.

General Operating Instructions

1. Wear ANSI-Approved safety goggles and heavy duty gloves during use.
2. Wear a good respirator breathing device.
3. To prevent accidents, turn off the tool and disconnect its power supply after use. Clean, then store the tool indoors out of childrens' reach.
4. Generally, when using this machine you will stand at the "open" side and feed the stock. The stock will be placed on the Conveyor Table on the left (infeed) and will travel to the right (outfeed). Use roller supports for long stock.
5. Do not stand directly in front of the infeed or outfeed end in case stock is accidentally ejected.
6. **Depth of cut.**
 - a. Depth of cut will vary depending on type of wood, and sandpaper grit.
 - b. Lower the conveyor table lower than necessary for the stock to be sanded to prevent the stock from being "grabbed" suddenly when the machine is turned on.

- c. Place the stock on the Conveyor Table (137) and raise the Conveyor Table until it is just a little below the sanding roller.
- d. Be sure the dust collection system is already in place. (See "Dust Bag" below.)
- e. Plug in and start the Drum Sander, then begin raising the Conveyor Table height while feeding the stock on the Conveyor Belt (165).
- f. Turning the Hand Wheel (103) 1/4 turn, is the most that is recommended at any one time.

7. **Dust Bag.**

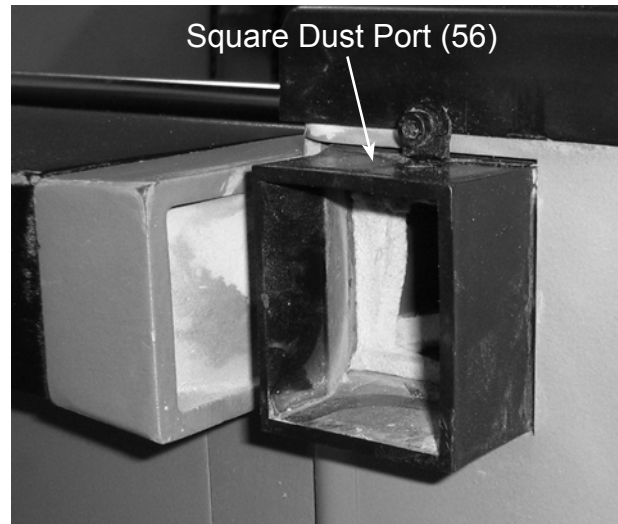

Fig. Square Dust Port

- a. The Dust Port Assembly should be mounted in place at this time. (See Attach Components c, d, e of "Final Assembly".)
- b. The Dust Port Assembly is composed of:
 - Square Dust Port (56)
 - Square-to-Round Dust Chute (59)
 - Dust Chute (70). (See the assembly drawing at the end of this manual.)



Dust Bag

c. The Dust Bag (273) is secured to the Dust Chute (70) with a Collar (218).

8. Speed adjustment.

- a. The speed of the Feed Belt (165) is adjusted by turning the Speed Adjustment Knob (74) *while the machine is running*.
- b. Turn the knob counterclockwise to increase the feed speed, clockwise to slow it down.

9. Sanding tips.

- a. If the stock is bowed, run it through with the high point on top and use light cuts.
- b. Feeding with the grain at an angle to feed direction will sand faster but for a finer finish, feed so direction of travel is straight with the grain.
- c. When done, turn Power Switch (105) off and unplug the power cord.

10. Sandpaper grit selection chart.

Grit	Class	Usage
36	Extra Course	Rough sawn boards, thicknessing and glue removal
60	Course	Thicknessing and glue removal
80-100	Medium	Removing sanding marks and initial finishing

Grit	Class	Usage
120-180	Fine	Finishing

- a. When changing grit, do not change by greater than a value of 50.

11. Sandpaper replacement.

a. Tools supplied:

- Hex keys - 4mm, 6mm
- Double open end wrench - 8mm, 12mm
- The Drum Sander comes with 80 grit sandpaper on the Drum (178) and a 150 grit Feed Belt (165).

b. Tools not supplied:

- Flat-end screwdriver
- Hex keys - 5mm, 8mm
- Roll of 3" wide sand paper
- Utility knife to cut sand paper

c. Disconnect the sander.

d. Open the Head Cover (186) and remove the three Hex Soc HD Scr (200) holding the Deflector Shield (187) and set aside.

e. The Sandpaper (179) is removed from the Drum (178) from right to left, and replaced from left to right.

f. Loosen the spring-loaded Locking Block (173) on the right by unscrewing the Hex Soc HD Scr (172) and use a screwdriver to loosen the Locking Block (173).

g. Remove the Sandpaper (179) from under the Locking Block and start unrolling it from right toward the left.

h. Loosen the left Locking Block (173).

i. Remove the old Sandpaper (179) carefully. This old sandpaper will be used as a template for the new one.

j. It would be advisable to save the sandpaper removed for this first change so it can be used for each subsequent replacements. Thus the

size and shape of the template will not change over time.

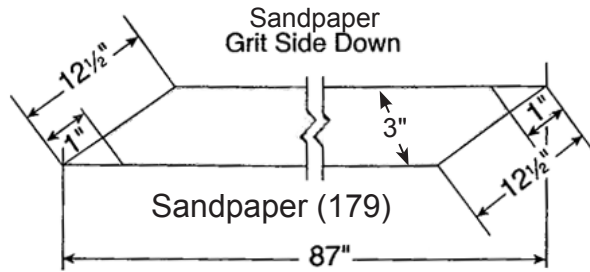

- k. After cutting the 12-1/2" angled sides, cut 1" from the greater length edge of both ends of the sandpaper strip as shown above.
- l. Place the left side of the new sandpaper under the left Locking Block (173) and tighten. The left side of the sandpaper must be flush with the Drum (178) edge (not over hanging).
- m. Start wrapping the sandpaper around the Drum so there are no air bubbles and no over-lapping edges.
- n. When reaching the right side, move the sandpaper out of the way, and position the 4mm hex wrench into the top of the Hex Soc HD Scr.
- o. Place the end of the sandpaper under the Locking Block and tighten the Hex Soc HD Scr (172).
- p. If the sandpaper does not line up properly when reaching the right-hand side. unwrap and repeat.
- q. Reinstall the Deflector Shield (187) and secure with the three Hex Soc HD Scr (172), and close the cover.

12. Cleaning the machine.

- a. Cleanup consists of vacuuming the various exterior and interior (hidden) areas of the sander.

13. Lubrication.

- a. Feed Bushings (135) need to be lubricated on a daily basis or with each use.

- b. These bushings (135) requiring oiling are located at each end of the Feed Belt Rollers (136, 156). Also, remove the Side Cover (82) and oil the drive bushings (29) as needed.

- c. Apply Lithium grease to all moving parts. This includes gears, chains, Feed Belt Rollers (136, 156) and Table's (137) lift mechanism.

- d. The moving and rotating parts of the Table's (137) lift mechanism including its Elevating Screws (162) must be cleaned free of old grease and fresh lithium grease applied as needed.

- e. Clean the teeth of the rotating helical-cut gear (113) and add fresh lithium grease. Raising and lowering the Table (137) spreads the grease to all rubbing parts.

14. Sanding Belts.

- a. Extend the life of the sand paper by using a crepe sanding pad (cleans build-up off the sandpaper) to remove material build-up.

15. V-Belt Tensioning.

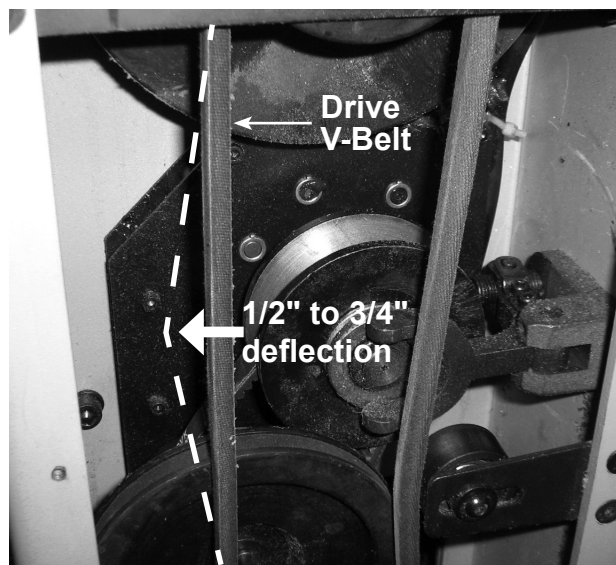

V-Belts

- a. Correct V-Belt tension is when the V-Belt can be deflected 1/2" - 3/4".

Test by pressing in the middle with a moderate amount of force.

- b. Turn off the sander and un-plug the power cord.
- c. Remove the pulley/V-Belt Side Cover (82).
- d. Check the V-Belts for signs of wear, deterioration or cracking. If any signs are visible, replace with a new belt.
- e. The Feed V-belt (99) is tensioned by loosening the Motor Bracket (100) screws and sliding the motor downward to tighten the V-Belt.
- f. The Drive V-Belt (97) is tensioned by pressing the tensioner Roller (255) against the V-belt, increasing pressure until the V-belt is of proper tension.
- g. These V-Belts are subject to stretching and loosening, so they must be checked on a regular basis and tensioned whenever necessary.
- h. Replace the pulley/V-Belt Side Cover (82).

MAINTENANCE AND SERVICING



Procedures not specifically explained in this manual must be performed only by a qualified technician.

⚠️ WARNING

TO PREVENT SERIOUS INJURY

FROM ACCIDENTAL OPERATION:

Turn the Power Switch of the tool to its “OFF” position and unplug the tool from its electrical outlet before performing any inspection, maintenance, or cleaning procedures.

TO PREVENT SERIOUS INJURY FROM TOOL FAILURE:

Do not use damaged equipment. If abnormal noise or vibration occurs, have the problem corrected before further use.

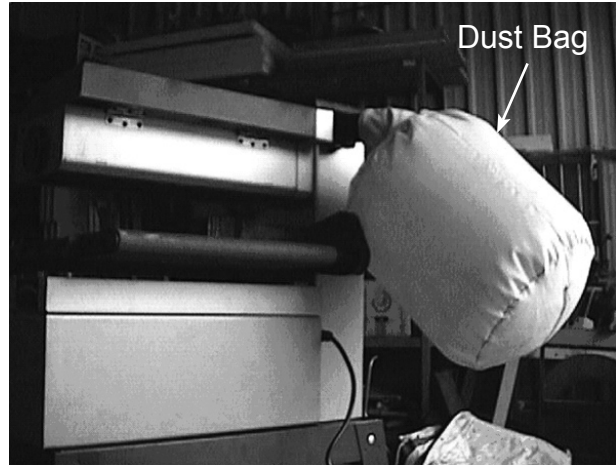

Dust Bag

3. If a dust collector is not used, clean out the Dust Bag (273) on a regular basis. (See Fig. “Dust Bag”) The frequency required will depend on hours of use, the type of stock being sanded, and the grit of sandpaper being used.
4. **⚠️ WARNING!** If the power cord of this power tool is damaged, it must be replaced only by a qualified service technician.

Cleaning and Maintenance

1. **BEFORE EACH USE**, inspect the general condition of the tool. Check for loose screws, misalignment or binding of moving parts, cracked or broken parts, damaged electrical wiring, and any other condition that may affect its safe operation.
2. **AFTER USE**, Brush and wipe external surfaces of the tool and vacuum if possible.

Replacing V-belts

1. Disconnect the Drum Sander from the electrical outlet.
 2. Open the Side Cover (82).
 3. To replace the variable-speed Drive Belt (97), loosen the cap screw securing the variable-speed Pulley (26, 28) before loosening the motor mount cap screws.
 4. Loosen the motor mount cap screws and the Pan Head screw (257) securing the tensioner roller.
 5. Remove the cap screws securing the Bearing Bracket (6) and rotate the Bearing Bracket 90°.
 6. Lift the motor, with a pry bar if necessary.
 7. To replace the variable-speed Drive Belt (97), remove the Hex Soc Hd Scr (16) securing the pulley, and remove the outer half of the pulley (26).
 8. Compress the Spring (20) behind the inner half of the Variable Speed Pulley (19). Slide the outer half of the pulley over the shaft (23) and Key (31) and thread in the Hex Soc Hd Scr.
 9. Install new Feed (99) and Drive V-belts (97), re-attach the Bearing Bracket, and tension according to instructions.
 10. Tighten the variable speed pulley cap screw and replace the Side Cover (82).
2. Open the Pulley Cover (108).
 3. If possible put a straightedge against the pulley faces or sight downward across the motor pulley and the feed pulley.
 4. If the pulleys are not aligned on the same plane, one of them needs to be adjusted.
 5. Moving a pulley requires removal of the V-belts.
 - a. Loosen the Set Screw on the Motor Pulley and align the Motor Pulley with the Feed Belt Pulley.
 - b. Tighten the set screws, replace the V-belts, and recheck alignment again.
 - c. If the Sanding Belt Pulley (43) needs to be aligned, loosen its Set Screw and adjust until it too is aligned with the Motor Pulley (98).
 - d. Repeat the adjustments until the pulley pairs are on the same plane with each other.
 - e. Replace the Pulley Cover (108).

Feed Belt Tracking

Feed belt tracking adjustment is a process taking trial-and-error to perform.

1. Turn the Feed Belt (165) "ON" and observe the tracking. If the feed belt moves to one side or the other, stop the belt immediately.
2. If the Feed Belt tracks toward one side, loosen the lock nut on that side and tension the adjustment screw until the belt tracks in the opposite direction. If the belt continues to track to one side, turn the Drum Sander

Pulley Alignment

1. Disconnect Drum Sander from the electrical outlet.

off and perform tracking adjustment again.

3. The belt should no longer move to one side during continuous use. The Conveyor Table (137) should not move up or back and forth
4. Do not over tighten the Feed Belt.
5. Lock the Feed Belt tensioning bolts by tightening the lock nuts.

Feed Belt Replacement

1. Disconnect the Drum Sander.
2. Mark the front of the Feed Belt tensioning bolt with a crayon or marker of some kind so that it can be replaced to its original position.
3. Loosen the lock nuts and turn both feed belt adjustment bolts counterclockwise a full turn at a time to release tension.
4. Remove the outside cap screws and loosen the corresponding cap screws on the inside edge.
5. Have a helper lift the outside edge of the Conveyor Table (137) and slide the feed belt off.
6. In reverse order, install a new feed belt after cleaning off the the Conveyor Table and its surrounding area.
7. Re-install the Conveyor Table cap screws. Tighten the cap screws. Perform the previously explained tensioning and tracking procedures.
8. Check for tension and tracking on a regular basis.

Conveyor Table Adjustments

1. Disconnect the power cord from the electrical outlet.
2. Remove the sandpaper from the drum and place previously prepared gauge blocks at either side of the Feed Belt (165).
 - a. Gauge blocks are prepared by taking two 2" x 4"s and jointing one side of each until the sides are absolutely flat.
 - b. Place the jointed edge against a table saw fence and cut a little off the un-jointed edge. Repeat for the other block.
 - c. This gives two gauge blocks that are exact in height.
3. With the gauge blocks in place, the distance from each end of the sanding Drum (178) to the Conveyor Table (137) should be the same. Adjust one side or the other until the distances are perfectly equal.
4. Raise the Conveyor Table until the gauge blocks just touch the Drum (178).
 - a. **Check rear of the Pressure Plate (84) adjustment:**
 - Use feeler gauges.
 - If the gap is more than 0.004" the rear of the Pressure Plate (84) must be adjusted.
 - b. **Check front of the Pressure Plate adjustment:**
 - Use feeler gauges.
 - If the gap is more than 0.004", the front of the Pressure Plate (84) must be adjusted.

5. **To adjust the rear Pressure Plate:**

- a. Disconnect the power cord from the outlet.
- b. Loosen the lock nuts and tighten the cap screws on both ends of the rear of the Pressure Plate (84) to raise or loosen to lower the plate.
- c. Adjust until the rear of the Pressure Plate (84) until it is at or up to 0.004" lower than the drum.

To adjust the front of the Pressure Plate:

- d. Disconnect the Drum Sander.
- e. Loosen the lock nuts and tighten the cap screws on both ends of the front of the Pressure Plate to raise the plate or loosen to lower.
- f. Adjust until the front of the Pressure Plate is up to 0.004" lower than the drum.

Wiring Diagram

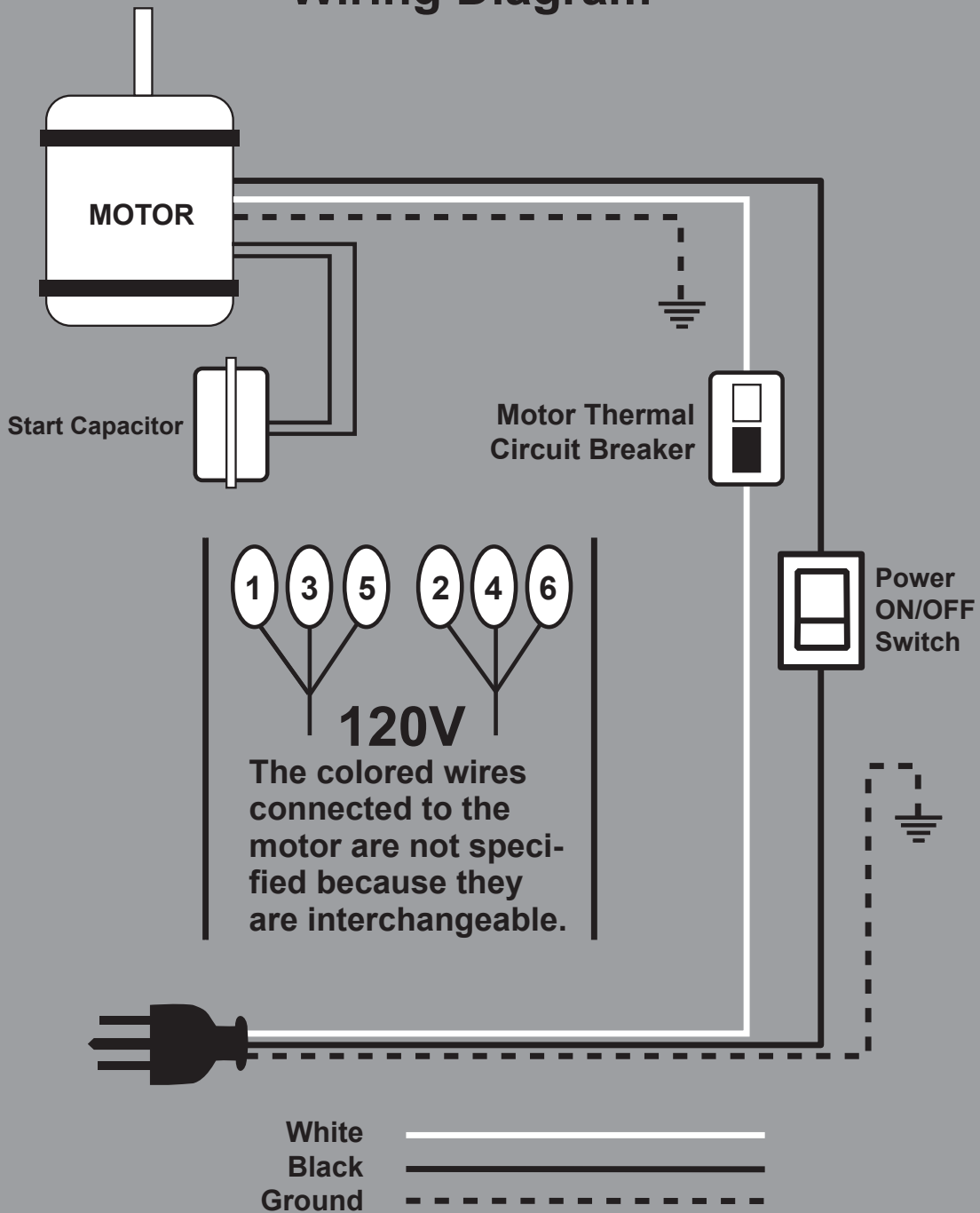

Troubleshooting

Problem	Possible Causes	Likely Solutions
<p>Tool will not start or trips the breaker.</p>	<ol style="list-style-type: none"> 1. Plug/outlet faulty or wired wrong. 2. Start capacitor is faulty. 3. Motor connection incorrectly wired. 4. Power supply is faulty, or is switched off. 5. Safety switch key is at fault. 6. Motor ON/OFF switch faulty. 7. Centrifugal switch faulty. 8. Cable or wiring is open or has high resistance. 9. Motor is at fault. 	<ol style="list-style-type: none"> 1. Test plug and outlet for good contact and correct wiring. 2. Test capacitor and replace if necessary. 3. Correct motor wiring. 4. Make sure hot lines and grounds are operational and have correct voltage on all legs. 5. Install or replace safety key, or replace switch assembly. 6. Replace faulty ON/OFF switch. 7. Adjust or replace centrifugal switch. 8. Check for disconnected or corroded connections, troubleshoot wires for internal or external breaks, then repair or replace wiring. 9. Test, then repair or replace the motor.
<p>Machine stalls or is underpowered</p>	<ol style="list-style-type: none"> 1. Wiring workpiece material. 2. Low power supply voltage. 3. Run capacitor is faulty. 4. Filter bags are at fault 5. V-belts are slipping. 6. Plug or outlet is at fault. 7. Motor connections are wired incorrectly. 8. Motor bearings are at fault. 9. Motor has overloaded. 10. Motor has overheated. 11. Centrifugal switch is at fault. 12. Motor is at fault. 	<ol style="list-style-type: none"> 1. Only process wood with proper moisture content and having no glues or resins. 2. Ensure hot lines and grounds are operational and have correct voltage on all legs. 3. Test capacitor and replace if necessary. 4. Empty and clean filter bags. 5. Replace bad belts, align pulleys, and re-tension the V-belts. 6. Test power plug and outlet for good contact and correct wiring. 7. Correct motor wiring. (See Wiring Diagram Pg. 19.) 8. Rotate motor shaft for noisy or burnt bearing, repair/replace as required. 9. Use sandpaper of the proper grit and reduce the feed rate/depth of sanding. 10. Check motor-cooling air flow, let motor cool and reduce workload on machine. 11. Adjust/replace centrifugal switch. 12. Test motor and repair/replace if necessary.

Troubleshooting Cont.

Problem	Possible Causes	Likely Solutions
Machine has vibration or noisy operation.	<ol style="list-style-type: none"> 1. Motor or component is loose. 2. V-belts are worn or loose. 3. Motor fan is rubbing on fan cover. 4. Pulley is loose. 5. Machine is incorrectly mounted to the floor. 6. Cast-iron motor mount is at fault. 7. Motor bearings are at fault. 	<ol style="list-style-type: none"> 1. Inspect for stripped/damaged bolts/nuts, replace/re-tighten with thread locking fluid. 2. Inspect belts, replace and re-tension. 3. Replace dented fan cover/damaged fan. 4. Remove pulley, replace shaft, pulley, set-screw and key as required and realign. 5. Machine has loose anchor studs in floor, or is sitting on uneven floor. Replace/tighten or relocate as soon as required. 6. Using leverage and a small pry bar to inspect, carefully replace loose/broken mounts. 7. Check bearings, replace motor or bearings as required.

Sanding Operations

Problem	Possible Causes	Likely Solutions
Vibration when sanding	<ol style="list-style-type: none"> 1. Loose drum bearings (215) 2. Worn drum bearings (215) 	<ol style="list-style-type: none"> 1. Tighten drum bearings. 2. Replace drum bearings.
Grinding, screeching, or rubbing noise when sanding drum is powered up.	<ol style="list-style-type: none"> 1. Drum bearings lack sufficient oil. 2. Drum bushings (206) are worn and need replacing. 	<ol style="list-style-type: none"> 1. Oil the drum bearings. 2. Replace the drum bushings.
Short V-belt lifespan	<ol style="list-style-type: none"> 1. Pulleys not aligned correctly. 2. Improperly tensioned. 	<ol style="list-style-type: none"> 1. Align pulleys to be on same plane. 2. Properly tension V-belts.
Machine lacks power; drum stops turning under load.	<ol style="list-style-type: none"> 1. V-belts are loose. 2. Too much pressure on pressure plate (84). 	<ol style="list-style-type: none"> 1. Tighten V-belts 2. Raise the pressure plates.
Feed belt slips under load.	<ol style="list-style-type: none"> 1. Feed belt is too loose. 2. Too much load. 	<ol style="list-style-type: none"> 1. Tension the V-belts. 2. Decrease the load.
Feed belt tracks to one side and hits the feed table mounts.	<ol style="list-style-type: none"> 1. Feed belt tracking is incorrect. 	<ol style="list-style-type: none"> 1. Adjust feed belt tracking.
Excessive snipe.	<ol style="list-style-type: none"> 1. Lack of outfeed support. 2. Too much pressure from Pressure Plate (84). 3. Too much pressure from the rear of pressure plate (84). 	<ol style="list-style-type: none"> 1. Set up an outfeed table or have someone stand along open side of sander and retrieve the workpiece as it comes out. 2. Lower the Pressure Plate. 3. Lower the rear of Pressure Plate.
Workpiece kicks out of sander.	<ol style="list-style-type: none"> 1. Not enough pressure from the pressure plate (84). 	<ol style="list-style-type: none"> 1. Raise the Pressure Plate.

Problem	Possible Causes	Likely Solutions
Sandpaper on Drum tears during operation	<ol style="list-style-type: none"> 1. Possibly a nail/staple in workpiece. 2. Sandpaper not tightened or fastened correctly. 	<ol style="list-style-type: none"> 1. Sand only clean workpieces. 2. Install the sandpaper correctly.
Table elevation controls are stiff and hard to adjust.	<ol style="list-style-type: none"> 1. Table lift screws are dirty or loaded with sawdust. 2. Chain idler sprocket Cap Screws have been over tightened. 3. Elevation handle helical gear is dirty or loaded with sawdust. 	<ol style="list-style-type: none"> 1. Clean and re-grease table lift screws. 2. Adjust the Cap Screws on the Idler Sprocket so it can rotate freely. 3. Clean and re-grease the Helical Cut Gear (113).



**Follow all safety precautions whenever diagnosing or servicing the tool.
Disconnect power supply before service.**

PLEASE READ THE FOLLOWING CAREFULLY

THE MANUFACTURER AND/OR DISTRIBUTOR HAS PROVIDED THE PARTS LIST AND ASSEMBLY DIAGRAM IN THIS MANUAL AS A REFERENCE TOOL ONLY. NEITHER THE MANUFACTURER OR DISTRIBUTOR MAKES ANY REPRESENTATION OR WARRANTY OF ANY KIND TO THE BUYER THAT HE OR SHE IS QUALIFIED TO MAKE ANY REPAIRS TO THE PRODUCT, OR THAT HE OR SHE IS QUALIFIED TO REPLACE ANY PARTS OF THE PRODUCT. IN FACT, THE MANUFACTURER AND/OR DISTRIBUTOR EXPRESSLY STATES THAT ALL REPAIRS AND PARTS REPLACEMENTS SHOULD BE UNDERTAKEN BY CERTIFIED AND LICENSED TECHNICIANS, AND NOT BY THE BUYER. THE BUYER ASSUMES ALL RISK AND LIABILITY ARISING OUT OF HIS OR HER REPAIRS TO THE ORIGINAL PRODUCT OR REPLACEMENT PARTS THERETO, OR ARISING OUT OF HIS OR HER INSTALLATION OF REPLACEMENT PARTS THERETO.

PART	PART NAME	Qty
1	SPRING WASHER	4
2	PAN HEAD SCREW	6
3	FLAT WASHER	6
4	HEX SOC HD SCR	4
5	BEARING RETAINER	2
6	BEARING BRACKET	1
7	HEX SOC HD SCR	4
8	CROSS PAN HEAD SCREW	1
9	C-RING	2
10	SPRING WASHER	1
11	SPONGE STRIP	1
12	SPONGE STRIP	1
13	HEX WRENCH	1
14	HEX WRENCH	1
15	HEX WRENCH	1
16	HEX SOC HD SCR	1
17	FLAT WASHER	1
18	PULLEY	1
19	PULLEY	1
20	SPRING	1
21	SPACER	1
22	BEARING(6003ZZ)	2
23	SHAFT	1
24	BEARING(6002ZZ)	3
25	THRUST BALL BEARING(51105)	1
26	PULLEY	1
27	BELT(400VK15-22)	1
28	PULLEY	1
29	DRIVE BUSHING	7
30	GEAR(SMALL)	2
31	KEY	2
32	SHAFT	1
33	HEX SOC HD SCR	7
34	INSIDE COVER	1
35	HEX SOC HD SCR	3
36	SHAFT	1
37	SPACER	7
38	SPECIAL WASHER	7
39	GEAR(SMALL)	1
40	BEARING(6004ZZ)	1
41	BEARING COVER	1
42	GEAR(SMALL)	1
43	PULLEY	1
44	SPACER	3
45	INSIDE COVER	1
46	SPROCKET	1

47	FAN	1
48	HEX SOC HD SCR	4
49	EXT RET RING	1
50	SET SCREW	1
51	KEY	1
52	FAN COVER	1
53	HEX SOC HD SCR	5
54	SET SCREW	1
56	SQUARE DUST TUBE	1
57	PAN HEAD SCREW	2
58	PAN HEAD SCREW	1
59	SQUARE-TO-ROUND DUST CHUTE	1
60	LINK	1
61	PIN	1
62	SPRING WASHER	2
63	HEX SOC HD SCR	2
64	SET SCREW	1
65	BRACKET	1
66	ADJUSTING ROD	1
67	HEX NUT	2
68	RETAINER	2
69	NUT	1
70	DUST CHUTE	1
71	HEX SOCKET HEAD SCREW	8
72	PAN HEAD SCREW	1
73	FLAT WASHER	1
74	KNOB	1
76	SPEED SCALE	1
77	GEAR	1
78	HEX SOC HD SCR	2
79	HEX SOC HD SCR	2
80	SET SCREW	2
81	FLAT WASHER	2
82	SIDE COVER	1
83	GEAR	1
84	PRESSURE PLATE	1
85	CHAIN	1
86	SIDE CASTING	1
87	FLAT WASHER	3
88	HEX SOC HD SCR	4
89	FLAT WASHER	2
90	TURNMETER COVER	1
91	CROSS PAN HEAD SCREW	4
92	SPROCKET	2
93	SPACER	1
94	IDLER BRACKET	1
95	SET SCREW	1
96	KEY	1

97	BELT(A46)	1
98	PULLEY	1
99	BELT(026)	1
100	MOTOR BRACKET	1
101	LOWER CASTING	1
102	SHAFT	1
103	HAND WHEEL	1
104	KEY WAY	1
105	SWITCH	1
106	SPROCKET	4
107	HEX SCR HD SCR	4
108	PULL COVER	1
109	BEARING(6904ZZ)	4
110	EXT RET RING	2
111	BEARING COVER	4
112	PAN HEAD SCREW	11
113	HELICAL-CUT GEAR	1
114	SET SCREW	2
115	WORM	1
116	BRACKET	1
117	HEX SOC HD SCR	4
118	SIDE COVER	1
119	TAP SCREW	3
120	PAN HEAD SCREW	1
121	DUST COVER	4
122	FIXED COLLAR	1
123	EXT RET RING	1
124	SPROCKET	1
125	FEED BUSHING	1
126	SPACER	1
127	CHAIN COVER	1
128	HEX SOC HD SCR	2
129	FLAT WASHER	2
130	GUIDE PLATE	1
131	FLAT WASHER	1
132	HEX SOC HD SCR	1
133	EXT RET RING	4
134	EXTENSION BRACKET	2
135	FEED BUSHING	4
136	FEED BELT ROLLER	1
137	CONVEYOR TABLE	1
138	HEX HEAD SCREW	2
139	HEX NUT	2
140	HEX SOC HD SCR	4
141	FLAT WASHER	4
142	HEX SOC HD SCR	1
143	FLAT WASHER	1
144	SPROCKET	1

145	WAVE WASHERS	1
146	CHAIN	1
147	SPACER	1
148	NUT	1
149	SPRING	1
150	TENSION WHEEL ASSY	1
151	CHAIN PROTECTOR	1
152	PAN HEAD SCREW	1
153	PAN HEAD SCREW	2
154	EXT RET RING	1
155	SPACER	1
156	FEED BELT ROLLER	1
157	HEX SOC HD SCR	4
158	FLAT WASHER	4
159	EXTENSION BRACKET	2
160	FLAT WASHER	4
161	HEX SOC HD SCR	4
162	ELEVATING SCREW	4
163	HEX NUT	1
164	EYE BOLT	1
165	FEED BELT	1
166	BEARING(6205ZZ)	1
167	HEX SOC HD SCR	2
168	HEX SOC HD SCR	4
169	NYLON CABLE GALND	1
170	BEARING SEAT	1
171	EXT RET RING	3
172	HEX SOC HD SCR	2
173	LOCKING BLOCK	2
174	FIXED PAN	1
175	FIXED PAN	1
176	HEAD SHAFT	1
177	KEY	2
178	DRUM	1
179	SANDER PAPER	1
180	SCREW	3
181	FIXED PAN	1
182	SPRING	1
183	HEX SOC HD SCR	1
184	HEX SOC HD SCR	4
185	FIXED PAN	1
186	HEAD COVER	1
187	DEFLECTOR SHIELD	1
188	SIDE COVER	1
189	SPONGE STRIP	1
190	HEX SOC HD SCR	4
191	CHIP BRECKER	1
192	BRACKET	2

193	PIN	2
194	HEAD COVER HANDLE BUSHING	2
195	HEAD COVER HANDLE	1
196	PAN HEAD SCREW	4
197	HEX SOC HD SCR	9
198	PIVOT	2
199	PAN HEAD SCREW	12
200	HEX SOC HD SCR	3
201	CHIP DEFLECTOR PLATE	1
202	FLAT HEAD SCREW	3
203	FLAT HEAD SCREW	5
204	SET SCREW	2
205	HEX NUT	2
206	DRUM BUSHING	2
207	HEX SOC HD SCR	1
208	HEX SOC HD SCR	4
208.1	SPRING WASHER	4
209	HEX SOC HD SCR	4
210	CHIP BRECKER	1
211	LINK	2
212	HEX SOC HD SCR	4
213	SPRING SHEET	2
214	HEADCASTING	1
215	BEARING	1
216	BEARING COVER	1
217	HEX SOC HD SCR	3
218	DUST HOSE COLLAR	1
219	HEX NUT	2
220	SET SCREW	2
221	FLAT WASHER	4
222	HANDLE	1
223	SWITCH RESET	1
224	SPRING WASHER	4
225	OPEN END WRENCH	1
226	PAN HEAD SCREW	2
227	EXT TOOTH WASHER	2
228	SPACER	1
229	HEX SOC HD SCR	2
230	FLAT WASHER	2
231	PAN HEAD SCREW	1
232	CABLE CLAMP	1
233	POWER CORD	1
234	SPRING	2
235	PLATE	1
236	FLAT WASHER	1
237	SPRING PIN	1
238	FLAT WASHER	1

239	HEX SOC HD SCR	1
240	LOCK NUT	4
241	ROD	1
242	HEX SOC HD SCR	2
243	PLATE	2
244	FLAT WASHER	4
245	HEX SOC HD SCR	4
246	HEX NUT	2
247	ROD	1
248	HEX SOC HD SCR	2
249	SPACER	1
250	PIN	1
251	SPRING WASHER	4
252	SET SCREW	8
253	PULLEY COVER	1
254	PULLEY SHAFT	1
255	TENSIONER ROLLER	1
256	PAN HEAD SCREW	2
257	PAN HEAD SCREW	1
258	HEX SOC HD SCR	1
259	WASHER	1
260	WASHER	1
261	BEARING(6002ZZ)	1
262	WASHER	1
263	STAND	4
264	UPPER LONG BRACKET	2
265	LOWER SHORT BRACKET	2
266	LOWER LONG BRACKET	2
267	UPPER SHORT BRACKET	2
268	CARRIAGE BOLT	24
269	FLANGE NUT	24
270	HEX BOLT	4
271	HEX NUT	4
272	FLAT WASHER	8
273	DUST BAG	1
274	FLAT WASHER	2
275	HEX NUT	4
276	CONNECTING CORD	2
277	WASHER	4
278	HEX SCR HD SCR	4
279	HEX SOC HEAD SCREW	1
280	HEX NUT	1
281	BELT GUARD LABEL	1
282	IN SIDE LABEL	1
283	OUT SIDE LABEL	1
284	MAIN LABEL	1
285	SPEED CHANGE LABEL	1

ASSEMBLY DIAGRAM

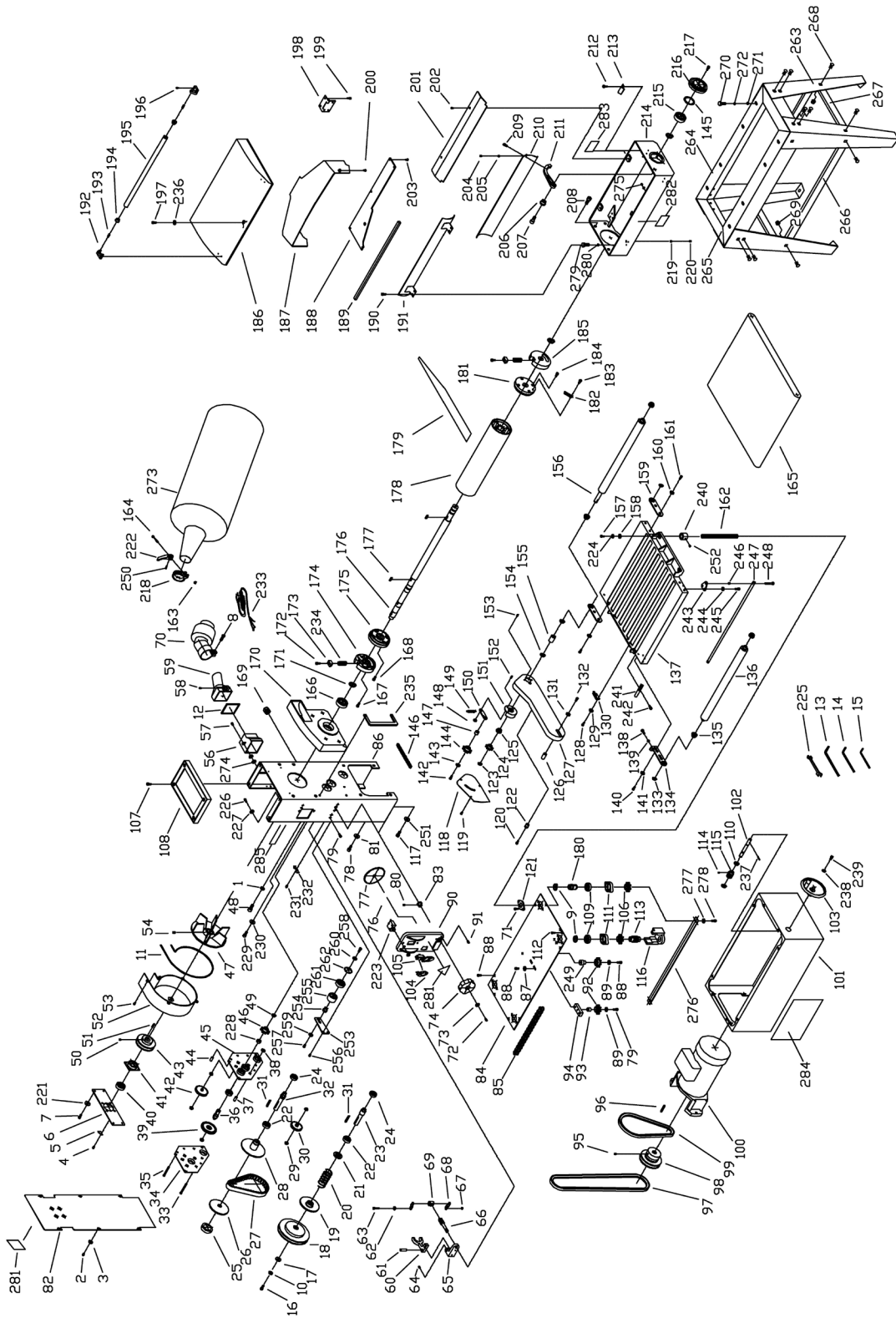

LIMITED 1 YEAR / 90 DAY WARRANTY

Harbor Freight Tools Co. makes every effort to assure that its products meet high quality and durability standards, and warrants to the original purchaser that for a period of ninety days from date of purchase that the engine/motor, the belts (if so equipped), and the blades (if so equipped) are free of defects in materials and workmanship. Harbor Freight Tools also warrants to the original purchaser, for a period of one year from date of purchase, that all other parts and components of the product are free from defects in materials and workmanship (90 days if used by a professional contractor or if used as rental equipment). This warranty does not apply to damage due directly or indirectly, to misuse, abuse, negligence or accidents, repairs or alterations outside our facilities, normal wear and tear, or to lack of maintenance. We shall in no event be liable for death, injuries to persons or property, or for incidental, contingent, special or consequential damages arising from the use of our product. Some states do not allow the exclusion or limitation of incidental or consequential damages, so the above limitation of exclusion may not apply to you. THIS WARRANTY IS EXPRESSLY IN LIEU OF ALL OTHER WARRANTIES, EXPRESS OR IMPLIED, INCLUDING THE WARRANTIES OF MERCHANTABILITY AND FITNESS.

To take advantage of this warranty, the product or part must be returned to us with transportation charges prepaid. Proof of purchase date and an explanation of the complaint must accompany the merchandise. If our inspection verifies the defect, we will either repair or replace the product at our election or we may elect to refund the purchase price if we cannot readily and quickly provide you with a replacement. We will return repaired products at our expense, but if we determine there is no defect, or that the defect resulted from causes not within the scope of our warranty, then you must bear the cost of returning the product.

This warranty gives you specific legal rights and you may also have other rights which vary from state to state.

3491 Mission Oaks Blvd. • PO Box 6009 • Camarillo, CA 93011 • (800) 444-3353

Record Product's Serial Number Here: _____

Note: If product has no serial number, record month and year of purchase instead.

Note: Some parts are listed and shown for illustration purposes only, and are not available individually as replacement parts.